

IDLER ARM

WITH TWO-HOLE FRAME BRACKET

Please read this document completely before starting installation.

Installation must be completed by a qualified automotive technician with proper tools. Refer to vehicle manufacturer's service manual for all fastener torque requirements.

INSTALLATION NOTICE

This Diamond Series® Idler Arm Assembly includes an improved *two-hole bracket design* which replaces the OE three-hole frame bracket. Some 1963-1964 Ford models *may be equipped with the three-hole bracket*. The two-hole bracket *will appear different* than the OE three-hole bracket. All Ford vehicles following 1964 have been changed to the two-hole bracket design.

NOTE: The lower frame hole is covered by the OE three-hole bracket (FIG. 1A).

Remove the OE three-hole bracket and thoroughly clean any dirt or debris from the frame hole shown in (FIG. 1A).

Install two-hole bracket using frame holes shown in FIG. 2A.

FIG. 1A

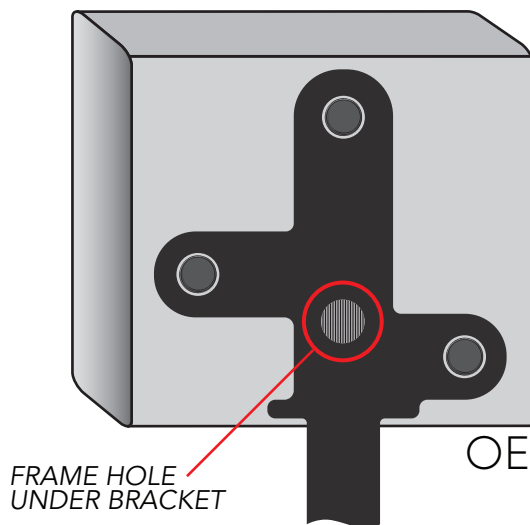
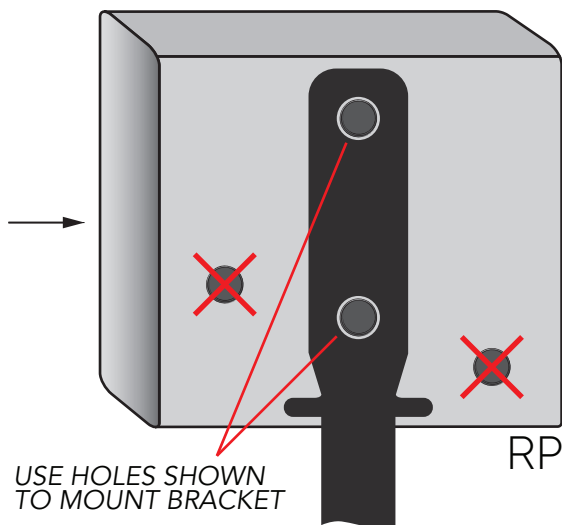

FIG. 2A



← FRAME →

TORQUE SPECIFICATIONS	STANDARD	GRADE 5	GRADE 8	METRIC	CLASS 8.8	CLASS 10.9	TAPER	1:8 IN/FT
	7/16 20 TPI	38 lb/ft	49 lb/ft	M10 1.25 TP	52 Nm	73 Nm	3/8 24 TPI	25-35 lb/ft
1/2 20 TPI	56 lb/ft	73 lb/ft	M12 1.25 TP	95 Nm	135 Nm	7/16 20 TPI	40-55 lb/ft	
9/16 18 TPI	76 lb/ft	100 lb/ft	M14 1.5 TP	150 Nm	210 Nm	1/2 20 TPI	55-65 lb/ft	
5/8 18 TPI	104 lb/ft	136 lb/ft	M16 1.5 TP	225 Nm	315 Nm	9/16 18 TPI	65-75 lb/ft	
3/4 16 TPI	173 lb/ft	225 lb/ft	M18 1.5 TP	325 Nm	460 Nm	5/8 18 TPI	75-90 lb/ft	
7/8 14 TPI	265 lb/ft	336 lb/ft	M20 1.5 TP	460 Nm	640 Nm	3/4 16 TPI	100-120 lb/ft	

Use of this product may change the handling characteristics of the vehicle. Operate vehicle carefully after installation. All information published on this document is for reference use only. 'Rare Parts, Inc.' assumes no liability for any losses or damages which occur from use of this product or information.

THANK YOU FOR PURCHASING RARE PARTS' IDLER ARM ASSEMBLY

800.621.2005 | RAREPARTS.COM